



OFFICINE MARIO DORIN SINCE 1918

**DORIN**<sup>®</sup>  
INNOVATION

# KARTA TECHNICZNA

Agregat skraplający

E-AU2-H2001CC



## Agregat skraplający Dorin E-AU2-H2001CC

Producent:	Dorin
Seria:	E-AU

### Dane techniczne:

Sprężarka:		H2001CC
Zasilanie sprężarki:	V/~/Hz	380-420/3/50 PWS
Max. prąd pracy sprężarki:	A	38,0
Pojemność zbiornika:	L	15,0
Waga netto:	kg	272
Waga brutto:	kg	306

### Dane techniczne skraplacza:

Przepływ powietrza:		13660
Wentylatory:	mm	2 x 500
Moc wentylatorów:	W	1360, 2 x 680
Prąd wentylatorów:	A	6

### Przyłącza:

ssawne:	mm	42
tłoczne:	cal	7/8"

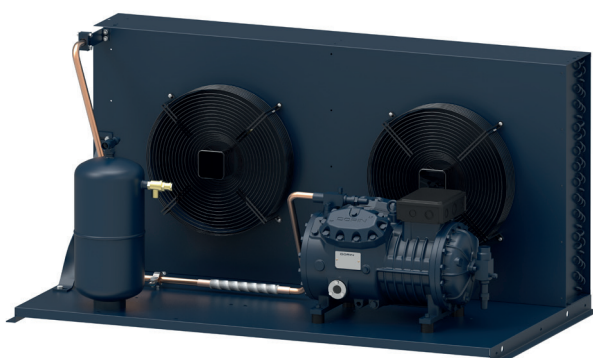

## Wydajność chłodnicza

Seria	Model	Czynnik	Wydajność chłodnicza Q <sub>0</sub> [W] (@ Tamb=35°C)									
			Temperatura parowania [°C]									
			+5	0	-5	-10	-15	-20	-25	-30	-35	-40
H41	E-AU2-H2001CC	R449A	47140	40090	33720	28010	23000	18560	14720	11430	8610	6190
		R404	46390	40600	35130	29990	25310	20990	17130	13710	10700	8090
			+20	+15	+10	+5	0	-5	-10	-15	-20	
		R134A	50440	43620	37290	31380	26010	21140	16870	13160	10020	-

## Pobór mocy z wentylatorami

Seria	Model	Czynnik	Pobór mocy z wentylatorami P [kW] (@ Tamb=35°C)									
			Temperatura parowania [°C]									
			+5	0	-5	-10	-15	-20	-25	-30	-35	-40
H41	E-AU2-H2001CC	R449A	19,21	17,25	15,35	13,51	11,76	10,14	8,71	7,52	6,63	6,13
		R404	20,16	18,17	16,35	14,67	13,12	11,69	10,38	9,17	8,08	7,11
			+20	+15	+10	+5	0	-5	-10	-15	-20	
		R134A	13,58	12,42	11,34	10,35	9,42	8,56	7,76	7,01	6,31	-

# Rys. techniczny

FL - wyjście freonu  
SL - zawór serwisowy na ssaniu  
SV - zawór bezpieczeństwa

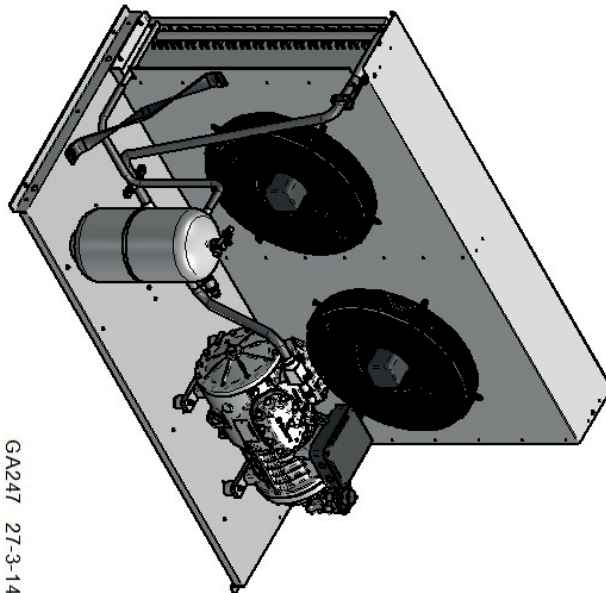
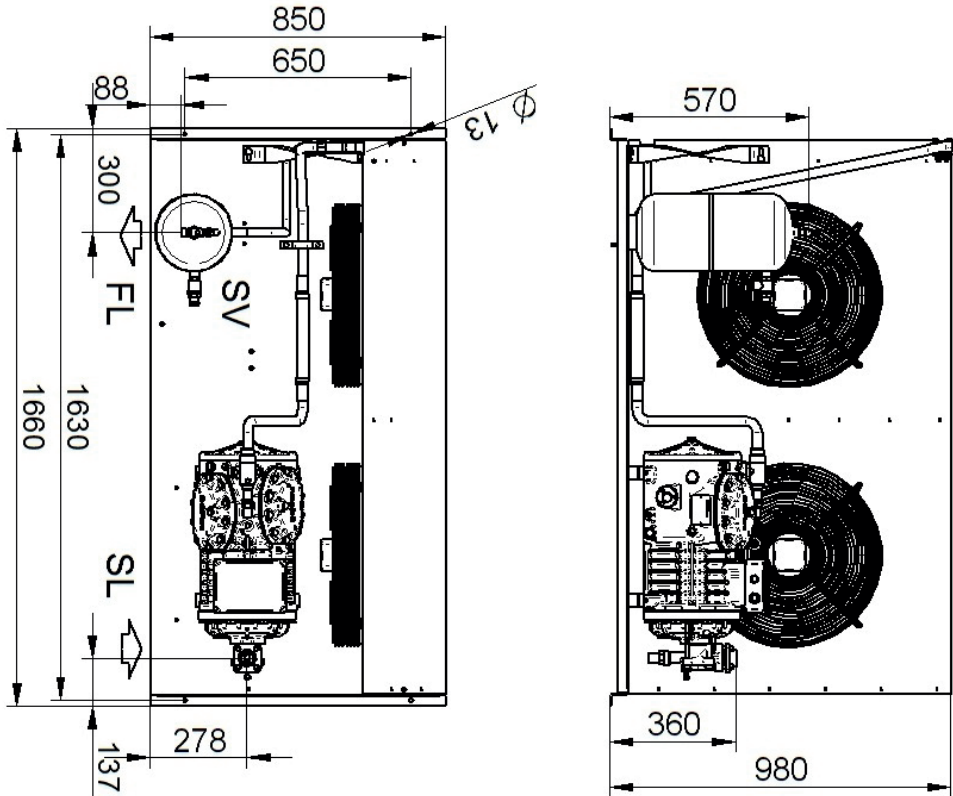

GA247 27-3-14

**E-AU2-H2001CC**

Sprężarka:  
H2001CC

Przyłącze  
sące

Przyłącze  
tłozące

42mm

7/8"