



OFFICINE MARIO DORIN SINCE 1918

DORIN[®]
INNOVATION

KARTA TECHNICZNA

Agregat skraplający

Dorin E-AU2-H1201CC



Agregat skraplający Dorin E-AU2-H1201CC

Producent:	Dorin
Seria:	E-AU

Dane techniczne:

Sprężarka:		H1201CC
Zasilanie sprężarki:	V/~/Hz	380-420/3/50 PWS
Max. prąd pracy sprężarki:	A	28,0
Pojemność zbiornika:	L	15,0
Waga netto:	kg	270
Waga brutto:	kg	304

Dane techniczne skraplacza:

Przepływ powietrza:		13660
Wentylatory:	mm	2 x 500
Moc wentylatorów:	W	1360, 2 x 680
Prąd wentylatorów:	A	6,0

Przyłącza:

ssawne:	mm	35
tłoczne:	cal	7/8"



Wydajność chłodnicza

Seria	Model	Czynnik	Wydajność chłodnicza Q ₀ [W] (@ Tamb=35°C)									
			Temperatura parowania [°C]									
			+5	0	-5	-10	-15	-20	-25	-30	-35	-40
H41	E-AU2-H1201CC	R449A	37410	31530	26280	21670	17610	14100	11090	8520	-	-
		R404	37800	32670	27950	23600	19680	16190	13070	10320	7920	5840
			+20	+15	+10	+5	0	-5	-10	-15	-20	
		R134A	40780	35020	29670	24770	20400	16510	13120	10200	7730	-

Pobór mocy z wentylatorami

Seria	Model	Czynnik	Pobór mocy z wentylatorami P [kW] (@ Tamb=35°C)									
			Temperatura parowania [°C]									
			+5	0	-5	-10	-15	-20	-25	-30	-35	-40
H41	E-AU2-H1201CC	R449A	13,10	12,14	11,14	10,09	9,04	8,00	7,00	6,08	-	-
		R404	12,01	13,02	12,01	10,99	9,95	8,92	7,92	6,97	6,11	5,35
			+20	+15	+10	+5	0	-5	-10	-15	-20	
		R134A	9,73	9,07	8,43	7,83	7,23	6,66	6,10	5,57	5,06	-

Rys. techniczny

FL - wyjście freonu
SL - zawór serwisowy na ssaniu
SV - zawór bezpieczeństwa

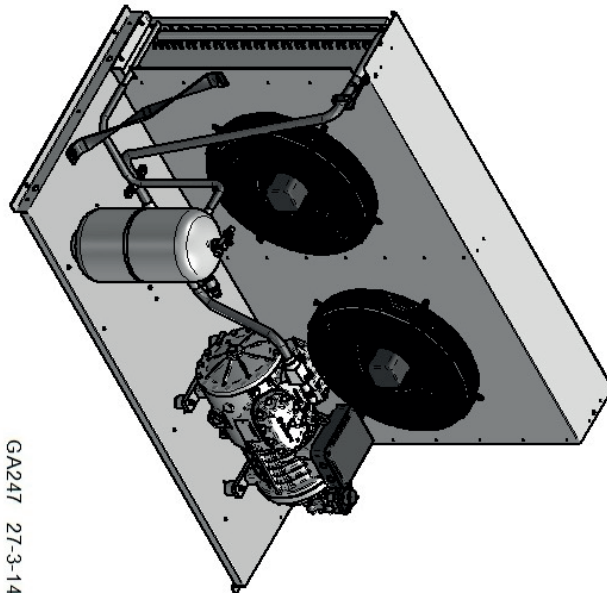
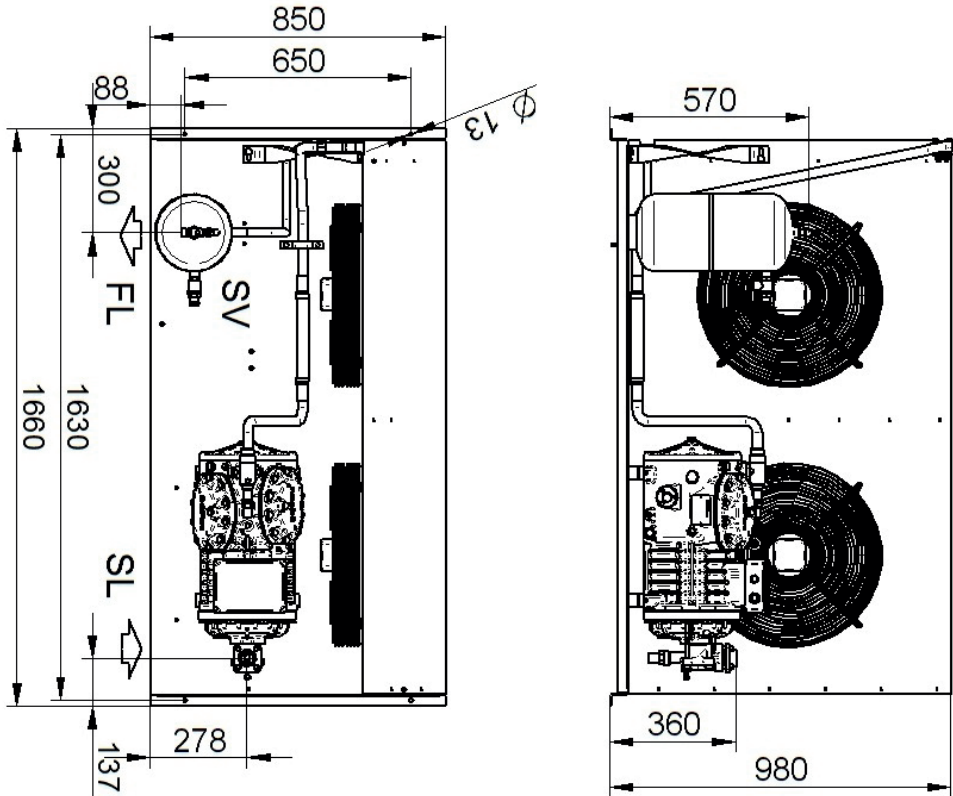

GA247 27-3-14

E-AU2-H1201CC

Sprężarka:
H1201CC

Przyłącze ssące	Przyłącze tłoczące
-----------------	--------------------

35mm	7/8"
------	------