



OFFICINE MARIO DORIN SINCE 1918

DORIN[®]
INNOVATION

KARTA TECHNICZNA

Agregat skraplający

Dorin E-AU4-H3000CC



Agregat skraplający Dorin E-AU4-H3000CC

Producent:	Dorin
Seria:	E-AU

Dane techniczne:

Sprężarka:		H3000CC
Zasilanie sprężarki:	V/~/Hz	380-420/3/50 (Y)
Max. prąd pracy sprężarki:	A	56,0
Pojemność zbiornika:	L	19,0
Waga netto:	kg	368
Waga brutto:	kg	

Dane techniczne skraplacza:

Przepływ powietrza:		21970
Wentylatory:	mm	4 x 450
Moc wentylatorów:	W	4 x 245
Prąd wentylatorów:	A	4,4

Przyłącza:

ssawne:	mm	54
tłoczne:	cal	7/8"



Wydajność chłodnicza

Seria	Model	Czynnik	Wydajność chłodnicza Q ₀ [W] (@ Tamb=35°C)									
			Temperatura parowania [°C]									
			+5	0	-5	-10	-15	-20	-25	-30	-35	-40
E-AU	E-AU4-H3000CC	R449A	69300	58870	49380	40780	33140	26410	20520	15490	11200	7610
		R404	67520	59050	52110	43690	36860	30560	24900	19840	15280	11220
			+20	+15	+10	+5	0	-5	-10	-15	-20	
		R134A	78120	68330	59020	50240	42030	34390	27520	21510	16340	-

Pobór mocy z wentylatorami

Seria	Model	Czynnik	Pobór mocy z wentylatorami P [kW] (@ Tamb=35°C)									
			Temperatura parowania [°C]									
			+5	0	-5	-10	-15	-20	-25	-30	-35	-40
E-AU	E-AU4-H3000CC	R449A	24,70	22,79	20,88	18,94	16,99	15,05	13,15	11,29	9,52	7,86
		R404	28,21	25,27	22,52	19,97	17,58	15,38	13,36	11,55	9,96	8,65
			+20	+15	+10	+5	0	-5	-10	-15	-20	
		R134A	20,24	18,82	17,36	15,86	14,36	12,86	11,38	9,93	8,56	-

Rys. techniczny

FL - wyjście freonu
SL - zawór serwisowy na ssaniu
SV - zawór bezpieczeństwa

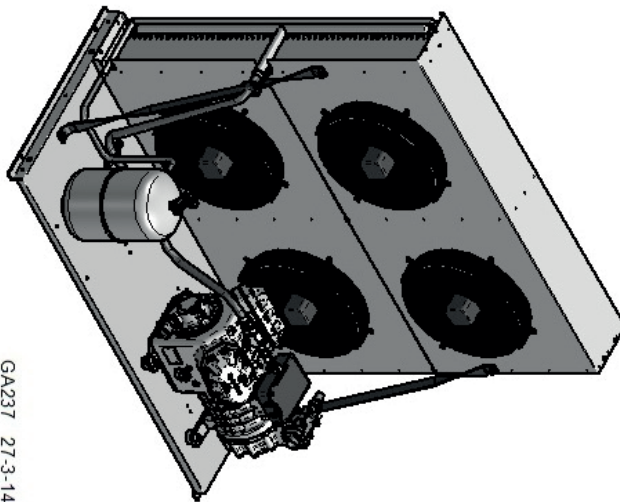
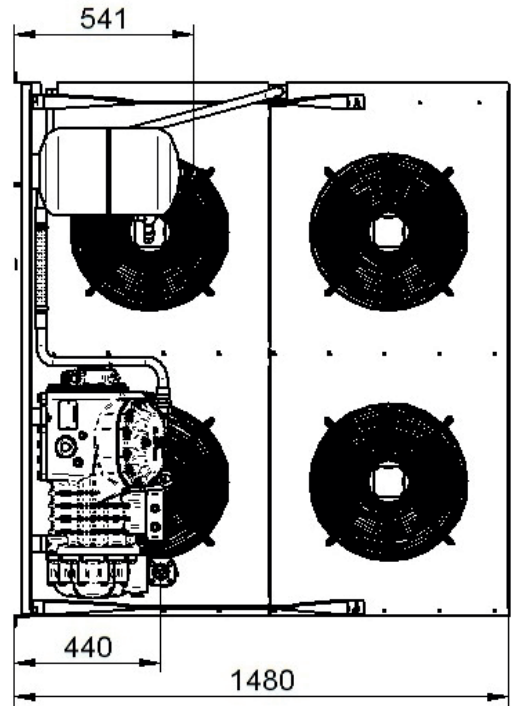
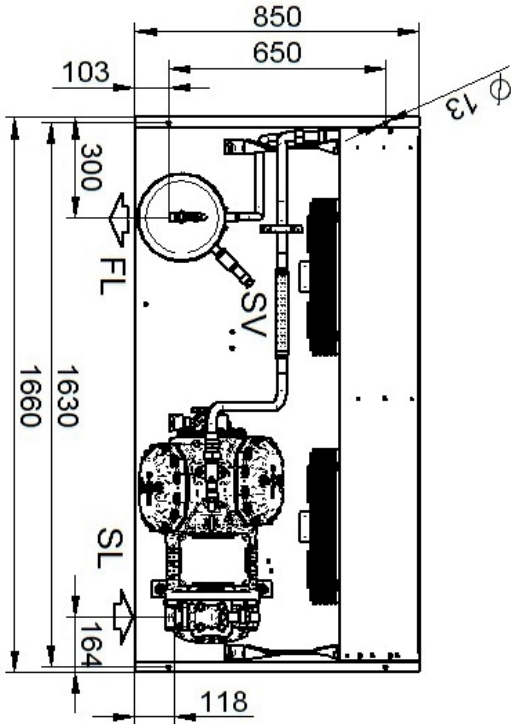

GA237 27-3-14

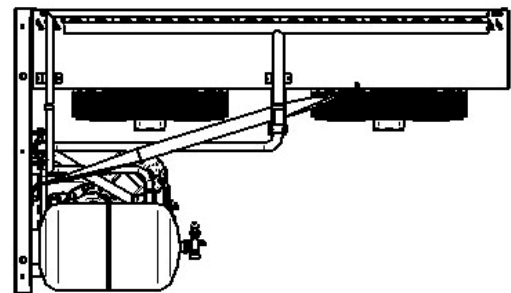

E-AU-H4 3000CC	
Sprężarka: H3000CC	
Przyłącze ssące	Przyłącze tłoczące
54mm	7/8"