



OFFICINE MARIO DORIN SINCE 1918

**DORIN**<sup>®</sup>  
INNOVATION

# KARTA TECHNICZNA

**Agregat skraplający**

**Dorin E-AU2-H1501CC**



## Agregat skraplający Dorin E-AU2-H1501CC

Producent:	Dorin
Seria:	E-AU

### Dane techniczne:

Sprężarka:		H1501CC
Zasilanie sprężarki:	V/~/Hz	380-420/3/50 PWS
Max. prąd pracy sprężarki:	A	34,0
Pojemność zbiornika:	L	15,0
Waga netto:	kg	271
Waga brutto:	kg	305

### Dane techniczne skraplacza:

Przepływ powietrza:		13660
Wentylatory:	mm	2 x 500
Moc wentylatorów:	W	2 x 680
Prąd wentylatorów:	A	6

### Przyłącza:

ssawne:	mm	42
tłoczne:	cal	7/8"



## Wydajność chłodnicza

Seria	Model	Czynnik	Wydajność chłodnicza Q <sub>0</sub> [W] (@ Tamb=35°C)									
			Temperatura parowania [°C]									
			+5	0	-5	-10	-15	-20	-25	-30	-35	-40
H41	E-AU2-H1501CC	R449A	41880	35500	29730	24600	20080	16150	12740	9840	7370	5280
		R404	40610	35670	31010	26620	22480	18690	15200	12080	9290	6840
			+20	+15	+10	+5	0	-5	-10	-15	-20	
		R134A	46110	39680	33760	28310	23360	18980	15120	11790	8960	-

## Pobór mocy z wentylatorami

Seria	Model	Czynnik	Pobór mocy z wentylatorami P [kW] (@ Tamb=35°C)									
			Temperatura parowania [°C]									
			+5	0	-5	-10	-15	-20	-25	-30	-35	-40
H41	E-AU2-H1501CC	R449A	16,09	14,56	13,10	11,70	10,37	9,11	7,95	6,92	6,03	5,33
		R404	16,45	15,25	14,03	12,79	11,56	10,34	9,16	8,05	7,03	6,13
			+20	+15	+10	+5	0	-5	-10	-15	-20	
		R134A	11,40	10,59	9,80	9,05	8,31	7,59	6,89	6,21	5,57	-

# Rys. techniczny

FL - wyjście freonu  
SL - zawór serwisowy na ssaniu  
SV - zawór bezpieczeństwa

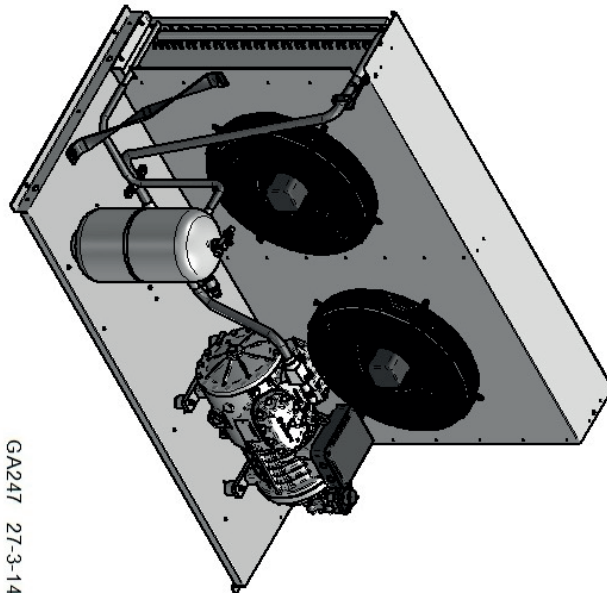
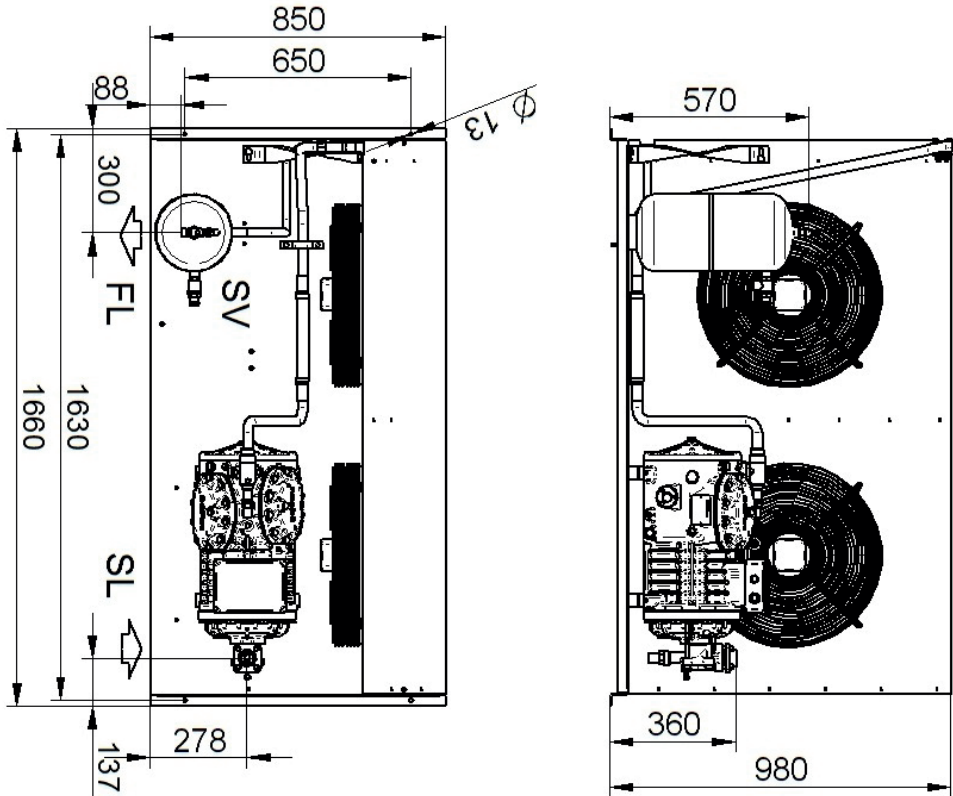

GA247 27-3-14

**E-AU2-H1501CC**

Sprężarka:  
H1501CC

Przyłącze  
sące

Przyłącze  
łóżące

42mm

7/8"