



OFFICINE MARIO DORIN SINCE 1918

DORIN[®]
INNOVATION

KARTA TECHNICZNA

Agregat skraplający

Dorin E-AU-H350CC



Agregat skraplający Dorin E-AU-H 350CC

Producent:	Dorin
Seria:	E-AU

Dane techniczne:

Sprężarka:		H350CC
Zasilanie sprężarki:	V/~/Hz	380-420/3/50 (Y)
Max. prąd pracy sprężarki:	A	9,4
Pojemność zbiornika:	L	5,7
Waga netto:	kg	110
Waga brutto:	kg	128

Dane techniczne skraplacza:

Przepływ powietrza:		5540
Wentylatory:	mm	1 x 450
Moc wentylatorów:	W	1 x 245
Prąd wentylatorów:	A	1,1

Przyłącza:

ssawne:	mm	28
tłoczne:	cal	5/8"



Wydajność chłodnicza

Seria	Model	Czynnik	Wydajność chłodnicza Q ₀ [W] (@ Tamb=35°C)									
			Temperatura parowania [°C]									
			+5	0	-5	-10	-15	-20	-25	-30	-35	-40
H2	E-AU-H350CC	R449A	13840	11690	9780	8080	6600	5320	4210	3270	2470	1790
		R404	14080	12190	10410	8800	7370	6080	4930	3930	3070	2330
			+20	+15	+10	+5	0	-5	-10	-15	-20	
		R134A	15380	13220	11220	9380	7750	6300	5030	3940	3020	-

Pobór mocy z wentylatorami

Seria	Model	Czynnik	Pobór mocy z wentylatorami P [kW] (@ Tamb=35°C)									
			Temperatura parowania [°C]									
			+5	0	-5	-10	-15	-20	-25	-30	-35	-40
H2	E-AU-H350CC	R449A	5,05	4,58	4,11	3,67	3,24	2,84	2,47	2,14	1,86	1,64
		R404	5,35	4,86	4,40	3,97	3,56	3,18	2,83	2,50	2,21	1,95
			+20	+15	+10	+5	0	-5	-10	-15	-20	
		R134A	3,47	3,25	3,04	2,83	2,62	2,41	2,21	2,01	1,81	-

Rys. techniczny

FL - wyjście freonu
SL - zawór serwisowy na ssaniu
SV - zawór bezpieczeństwa

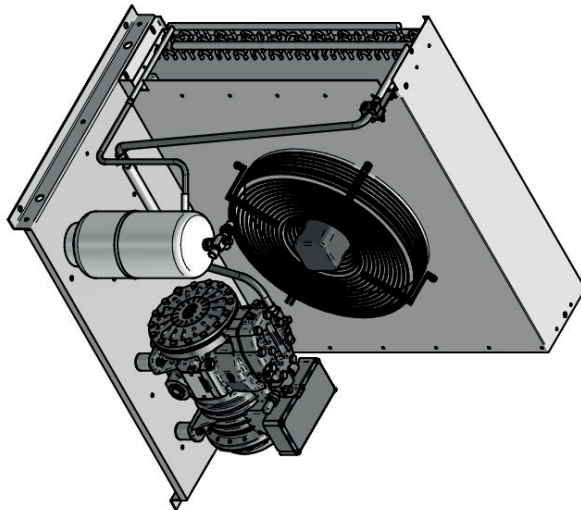
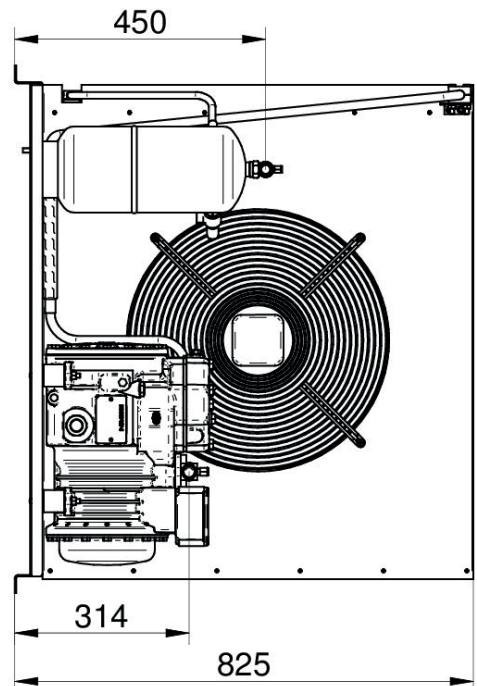
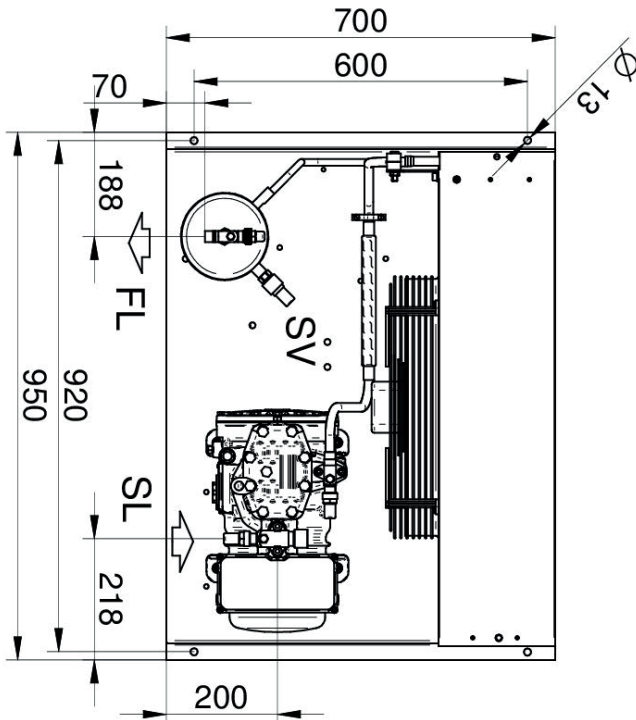

GA224 15-6-15

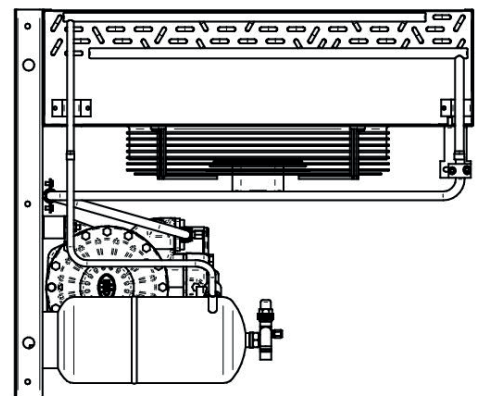

E-AU-H 350CC	
Sprężarka: H350CC	
Przyłącze ssące	Przyłącze tłoczące
28mm	5/8"